



Research Paper On Electrical Discharge Machining

Er. Ritesh Kumar Hui¹, Er. Jyoti ranjan Paikaray²

Senior Lecturer¹, Lecturer² Department Of Mechanical Engineering^{1,2}

Keywords

EDM, Electric Discharge Machining, Unconventional Manufacturing Process, TWR and MRR

Abstract

Ganesh Institute Of Engineering & Technology, Polytechnic, Bhubaneswar Abstract-By means of the improvement and growths in new machineries, low weight- high strength, high hardness and temperature resistant materials have been advanced for distinctive applications which include aerospace, medical, automobile and more. In the machining of hard and metal matrix composite materials, outdated manufacturing processes are being more and more changed by more nontraditional machining processes which include Electrical Discharge Machining (EDM). The work piece material designated in this experiment is Inconel 925 taking into interpretation its wide usage in industrial applications. In today's world stainless steel provides to nearly half of the world's production and consumption for industrial determinations. In this experiment the input variable factors are voltage, current and pulse on time. As we know that Taguchi method is functional to produce an L9 orthogonal array of input variables by means of the Design of Experiments (DOE). So, Taguchi method is used to analysis the output data. The consequence of the compliant parameters stated overhead upon machining characteristics such as Material Removal Rate (MRR) and Tool Wear Rate (TWR) is considered and examined. In this we are focused on to analysis minimum TWR and maximum MRR based on control factors and response parameters.

INTRODUCTION

Electrical discharge machining (EDM) EDM is most widely and successfully applied process in machining of hard metals or those that would be very difficult to machine with traditional techniques. The material is removed from the work piece by the thermal erosion process, i.e., by a series of recurring electrical discharges between a cutting tool acting as an electrode and a conductive workpiece in the presence of a dielectric fluid. This discharge occurs in a voltage gap (Vg) between the electrode and work piece. Heat from the discharge vaporizes minute particles of work piece material, which are then washed from the gap by the continuously flushing dielectric fluid. This technology is increasingly being used in tool, die and mould making industries, for machining of heat treated tool steels and advanced materials (super alloys, ceramics, and metal matrix composites) requiring high precision, complex shapes and high surface finish. Traditional machining technique is often based on the material removal using tool material harder than the work material and is unable to machine them economically. EDM is one of the most popular non-traditional material removals process and has become basic machining method for the manufacturing industries of aerospace, automotive, nuclear and medical.

With the increasing demands of high surface finish and machining of complex shape geometries, conventional machining process are now being replaced by non- traditional machining processes. Electrical discharge machining utilizes rapid, repetitive spark discharges from a pulsating direct current power supply between the

workpiece and the tool submerged into a dielectric liquid.

METHODOLOGY

The selection of the material and work piece on the basis of reviewed research paper and the selected tool is copper and work piece material is AISI 304L stainless steel. According to the taguchi method of experimental design the experiment has been done with 9 experimental run. The input parameter is current, Ton and Toff and output parameter is MRR. The researcher has selected the three level of input parameter. The parameters are current, Ton and Toff and the level of parameters are (6, 10, 14), (50, 100, 150), (8, 10, 12) respectively. Material removal rate (MRR), Electrode Wear Rate (EWR) and Signal to noise ratio is calculated as following

$$\text{MRR} = \frac{[(\text{weight before machining}) - (\text{weight after machining})]}{[(\text{time duration}) \times (\text{material density})]}$$

Wear Resistance (WR)

There are four different types of wear: volumetric, corner, end, and side (figure 6-3). Corner wear is usually the most important since it will determine the degree of accuracy of the final cut. If an electrode can successfully resist erosion at its most vulnerable points, then overall wear will be minimized and maximum electrode life achieved. The ability of an electrode material to produce and maintain detail is directly related to its resistance to wear and its machinability. Corner wear is also important if the electrode is to be dressed. The electrode will have to be dressedback beyond this worn area.

End wear — This is the reduction in the length of the electrode during the EDM process. The amount can be calculated by measuring the length of the electrode before the cut and after the cut and subtracting the length after the cut from the original length.

End Wear = Starting Length – Final Length

End wear ratio — The end wear ratio (work/wear) can be expressed as a percentage of the original usable length of the electrode. The depth of the machined cut in the workpiece is divided by the measured end wear. Dividing this number into 100 will result in the percentage of end wear.

$$\text{End Wear Ratio} = \frac{\text{Depth of Cut}}{\text{End Wear}}$$

$$\text{Percent End Wear} = \frac{100}{\text{End Wear Ratio}}$$

PROJECT DESIGN OF EDM

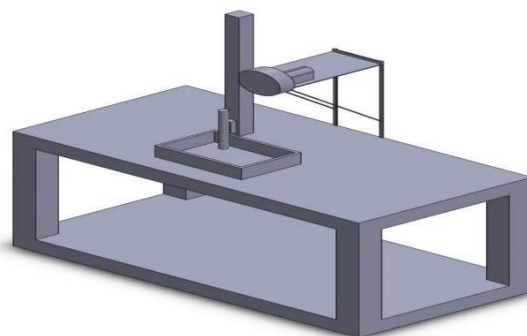

COST ESTIMATION

Sr. No	Part Name	Quantity	Configuration	Cost
1	IGBT	1	G4pc40s	350/-
2	Tool(BRASS)	1	5cm	350/-
3	Metal Sheet(STAND)	1	1mm sheet metal	50/-
4	Green Stand	4	EN 419	196/-
5	Yellow stand	1	HT106	190/-
6	Resistor	1	20ohm 2w	5/-
7	Step-Down Transformer	1	60v 4amp	2500/-
8	Diode	4	5408	50/-
9	Pulse Generator	1	5khz	700/-
10	Spark Capacitor	1	400v 100f	30/-
11	Motor	1	12V	150/-
12	Adapter	1	12v	150/-
13	Wheel	1	EN 923	76/-
14	Gear Stand	1	HT 101B	38/-
15	Plastic Box	1	15cm/6cm	10/-
16	Nuts bolts&packing	36	Round head ½ inch	150/-
17	Distilled water	1lit	Pure water	100/-
18	Switch	1	2 way	30/-
19	Tool holder	1	5inch	200/-
20	Copper Wire	5m	16amp	300/-
21	Ply	2	(2/1)*2	300/-
	Estimate Cost			5925/-

RESULT & DISCUSSIONResults for Material Removal Rate (MRR)

Weight of the workpiece material is taken before and after the machining on EDM and with help of weight and density, material removal rate is obtained. The Effect of input parameters on the output parameter is recorded in the table. Twentyseven experiments done on the electro discharge machine based on the taguchi method and summarized in the following table

S. No.	IP	T off	Ton	work before	Work after	Time	MRR
1	6	8	50	268.63	266.87	33	0.053333
2	6	8	100	266.87	265.03	32	0.0575
3	6	8	150	265.03	263.26	32	0.055312
4	6	10	50	263.26	261.43	28	0.065357
5	6	10	100	271.43	269.59	27	0.068148
6	6	10	150	259.59	257.73	26	0.071538
7	6	12	50	257.73	255.93	26	0.069231
8	6	12	100	255.93	254.12	26	0.069615
9	6	12	150	254.12	252.27	25	0.074
10	10	8	50	272.71	271.03	18	0.093333
11	10	8	100	271.03	269.21	17	0.107059
12	10	8	150	268.91	265.3	17	0.212353
13	10	10	50	267.3	265.56	15	0.116
14	10	10	100	265.56	263.69	14	0.133571
15	10	10	150	263.69	261.84	12	0.154167
16	10	12	50	261.84	260	14	0.131429
17	10	12	100	260	258.14	14	0.132857
18	10	12	150	258.14	256.26	13	0.144615
19	14	8	50	261.01	259.33	9	0.186667
20	14	8	100	259.33	257.48	8	0.23125
21	14	8	150	257.48	255.67	7	0.258571
22	14	10	50	255.67	254	8	0.20875
23	14	10	100	254	252.19	8	0.22625
24	14	10	150	252.19	250.37	7	0.26
25	14	12	50	250.37	248.7	8	0.20875
26	14	12	100	248.7	246.98	7	0.245714
27	14	12	150	245.54	243.05	6	0.415

CONCLUSION

EDM is now becoming a popular and elective method for micro-machining. This is due to its capability of producing a better surface finish on the machined materials. In order to maintain proper machining characteristics and performance, it is necessary to make sure that the optimum discharge gap between the electrode and the work piece is achieved. For round shaped electrodes MRR was the maximum followed by the square shaped electrodes. A round shaped electrode undergoes less wear then the square shaped electrode. It is because of no vulnerable sharp corner at the sparking tip. Cavities made by EDM die sinking may have intricate shapes and it is difficult to achieve high accuracy at the sharp corner of the cavities

ACKNOWLEDGEMENT

We would like to place a record of our deep sense of gratitude to. Department of Mechanical Engineering, SSPM's COEK ankavli, for his generous guidance, help and useful suggestions. We express our sincere gratitude to **Prof. Sachin V. Vanjari (Head of Mechanical Engineering Department)** for his simulating guidance and continuous encouragement throughout the course of present work. We also wish to extend our thanks to faculty members of **Department of Mechanical Engineering SSPM's COEK ankavli** for providing us infrastructure facilities to work in, without which this work would have not been possible. We are also grateful to our family members for their constant encouragement, extended cooperation and help.

REFERENCE

- [1]. P. Srinivasa Rao, J. Suresh Kumar, K. Vijaya Kumar Reddy, B. Sidda Reddy "Parametric Study Of Electrical discharge Machining Of Aisi 304 stainless Steel"
- [2]. Singh Jaspreet, Singh Mukhtiar and Singh Harpreet" Optimization of machining parameters of Electric Discharge Machining for 202 stainless steel" International Journal of Modern Engineering Research, Vol. 3, Issue. 4, Jul - Aug. 2013 pp-2166- 2169.
- [3]. MunmunBhaumik, Kali PadaMaity "Study the Effect of Tungsten Carbide Electrode on Stainless Steel (AISI 304) Material in Die Sinking EDM" Journal of Material Science and Mechanical Engineering Volume 1, Number 1; October, pp. 1-6, 2014. Pradeep Kumar P. "INVESTIGATION OF MATERIAL REMOVAL RATE IN
- [4]. Narinder Singh, Onkar Singh Bhatia," Analysis of the Influence of EDM Parameters on Material Removal Rate of Low Alloy Steel and Electrode Wear of Copper Electrode", International Journal of Advanced Research in Science, Engineering and Technology Vol. 3, Issue 6 , June 2016.