

Experimental Analysis on Quasi-Z-Source Cascade Multilevel Inverter-Based Grid-Tie Single-Phase Photovoltaic Power System

Prof. I.M. Vishal

ABSTRACT

An effective control method, including system-level control and pulsewidth modulation for quasi-Z-source cascade multilevel inverter (qZS-CMI) based grid-tie photovoltaic (PV) power system is proposed. The system-level control achieves the grid-tie current injection, independent maximum power point tracking (MPPT) for separate PV panels, and dc-link voltage balance for all quasi-Z-source H-bridge inverter (qZS-HBI) modules. The first solution comprises a full-SiC two-level QZS inverter, while the second design was built based on a three-level neutral-point-clamped QZS inverter with Silicon based Metal–Oxide–Semiconductor Field-Effect Transistors (Si MOSFETs). Several criteria were taken into consideration: the size of passive elements, thermal design and size of heatsinks, voltage stress across semiconductors, and efficiency investigation. The Photovoltaic (PV)-string rated at 1.8 kW power was selected as a case study system. The advantages and drawbacks of both solutions are presented along with conclusions.

INTRODUCTION

A recent upsurge in the study of photovoltaic (PV) power generation emerges, since they directly convert the solar radiation into electric power without hampering the environment. However, the stochastic fluctuation of solar power is inconsistent with the desired stable power injected to the grid, owing to variations of solar irradiation and temperature. To fully exploit the solar energy, extracting the PV panels' maximum power and feeding them into grids at unity power factor become the most important. The contributions have been made by the cascade multilevel inverter (CMI) [1], [2]. Nevertheless, the H-bridge inverter (HBI) module lacks boost function so that the inverter KVA rating requirement has to be increased twice with a PV voltage range of 1:2; and the different PV panel output voltages result in imbalanced dc-link voltages. The extra dc–dc boost converters were coupled to PV panel and HBI of the CMI to implement separate maximum power point tracking (MPPT) and dc-link voltage balance [3], [4].

However, each HBI module is a two-stage inverter, and many extra dc–dc converters not only increase the complexity of the power circuit and control and the system cost, but also decrease the efficiency.

Recently, the Z-source/quasi-Z-source cascade multilevel inverter (ZS/qZS-CMI)-based PV systems were proposed in [5]–[8]. They possess the advantages of both traditional CMI and Z-source topologies. For example, the ZS/qZS-CMI: 1) has high-quality staircase output voltage waveforms with lower harmonic distortions, and reduces/eliminates output filter requirements for the compliance of grid harmonic standards; 2) requires power semiconductors with a lower rating, and greatly saves the costs; 3) shows modular topology that each inverter has the same circuit topology, control structure and modulation [1], [2]; 4) most important of all, has independent dc-link voltage compensation with the special voltage step-up/down function in a single-stage power conversion of Z-source/quasi-Z-source network, which allows an independent control of the

power delivery with high reliability [9]; and 5) can fulfill the distributed MPPT [6], [8]. Continuous development and improvements of Photovoltaic (PV) system designs along with related technologies, such as Wide Bandgap (WBG) GaN/SiC devices, Digital Signal Processor (DSP)- and Field-Programmable Gate Array (FPGA)-based control units have gradually decreased their costs. This allows new solutions featuring high efficiency and easy implementation which make them commercially attractive. At the same time, power rates and voltage operation ranges determine the availability of certain PV applications, especially in small-scale installations. In addition to efficiency and power density, the reliability of PV inverters is the key factor influencing the feasibility of single-phase industrial implementations [1,2], where Full-Bridge (FB) Voltage-Source Inverters (VSIs) are mostly used. Many DC-AC solutions for connecting PV modules to a single-phase grid are discussed in Reference [3]. The relative costs assessed based on the calculated ratings, component surveys at different vendors, and linear regression analysis were also taken into account in the evaluation.

The Z-Source Inverter (ZSI) [4] is an alternative to VSIs and Current-Source Inverters (CSIs) due to its ability to provide buck-boost operation within the single stage and its improved reliability based on its natural immunity against short-circuit. Its benefits have made it a promising solution for PV systems and have urged investigations in this area, which has resulted in many DC-DC and DC-AC topologies for single-phase and three-phase applications [5-15]. The Quasi-Z-Source Inverter (QZSI) was derived from the ZSI and has become a desirable topology for PV applications [5] due to its inheritance of all the advantages of ZSI enhanced by lower component ratings and continuous input current. The application of multilevel inverters has advantages in higher power designs, where the high voltage stress on the inverter's switches can be avoided. The combination of the QZSI with

the Three-Level (3L) Neutral-Point-Clamped (NPC) inverter has created a new promising topology, described in detail in Reference [6]. It features certain advantages such as low voltage stress on the power switches, single-stage buck-boost operation, continuous input current, short-circuit immunity, and low total harmonic distortion of the output voltage and current.

A detailed comparative study of basic and derived impedance-source networks for buck-boost inverter applications is provided in Reference [7], mostly for three-phase applications. The investigation of loss distribution was addressed recently in References [8,9] for QZSI-based topologies along with methods for their reduction and efficiency improvement. Many publications devoted to the ZSI- and QZSI-derived solutions for PV, wind, and Microgrids applications have appeared recently. They address certain issues, such as current harmonics reduction, voltage gain improvement, leakage current reduction, etc. The authors of Reference emphasize the use of the coupled-inductor and SiC devices to optimize power density. A good comparison of impedance-source networks suitable for DC and AC applications by means of the passive components' number and size, semiconductor devices stress, and range of the input voltage variation is provided in Reference. The increased voltage stress across semiconductors was reported as the main drawback of ZSI/QZSI. High-voltage gain solutions with additional magnetic may mitigate this.

2. CASE STUDY SYSTEM

2.1. System Parameters and Specifications

The PV system being considered for PV string application which could comprise 5 : : : 10 PV panels with total power up to 1800W. The PV panel SPR-200-BLK from SunPower was selected for the case study. The main system and PV panels parameters are provided and typical P-V and I-V dependencies are shown in Figure 1. The operating power profile of the design solution according to the case study PV string is also depicted in Figure 1. In the input voltage

range from 200 V to 400 V, the converter was assumed to operate with the rated input current of 5 A.

Depending on the operating conditions and the type of panels, the power conversion efficiency can vary, but is aimed to be in the range from 92% to 96%. The converter was aimed to

operate at the rated (nominal) power of 1800W, with its maximum efficiency of 97.1% in the nominal mode, which corresponds to the input voltage of 360 V. In this operating point, the converter has its highest CEC efficiency, which is over 96% for both topologies (2L QZSI and 3L NPC QZSI).

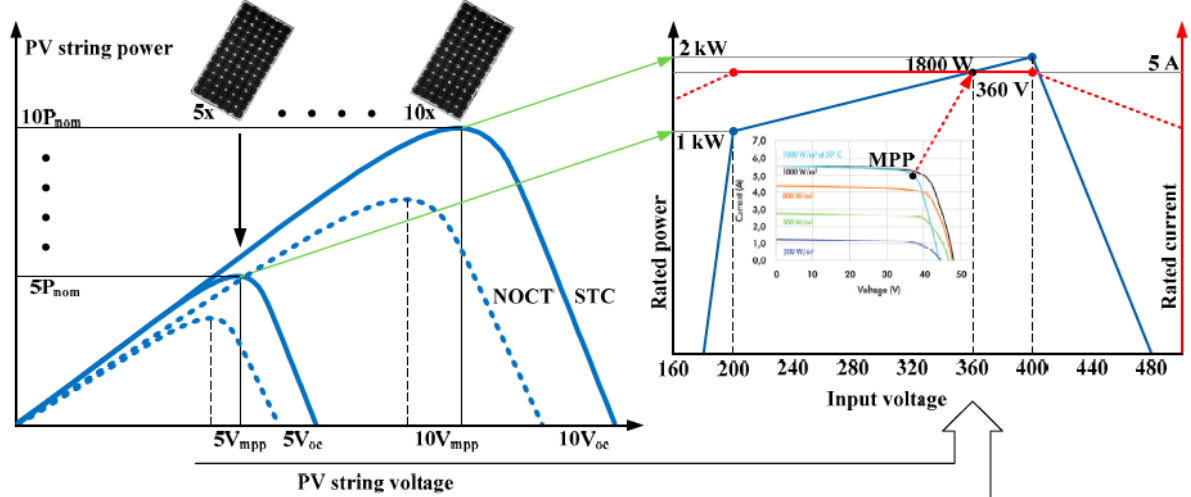

Figure 1. PV string characteristics and system power profile.

2.2. Description of Topologies

The PV system considered was built based on two different approaches: on the 2L QZSI (Figure 2) and on the 3L NPC QZSI (Figure 3). The 2L QZSI proposed in Reference [5] is described in detail as a three-phase application for PV systems. The main parts of the topology include the QZS network represented by L_1 , D_1 , C_1 , L_2 , and C_2 ; the FB 2L inverter based on MOSFET switches S_1 , S_2 , S_3 , and S_4 ; and the

output filter LF_1 , CF , and LF_2 feeding the load or connected to the grid. Detailed discussions and explanations on the 2L QZSI for a single-phase PV application as well as the control approaches, including SBC, MBC, constant boost control and their modifications, are provided. In this *stnuedrgyi,esS 2B0C19,w l2a, sx uFOseRd PfEoErRg ReEnVeIEraWti ng the ST states.*

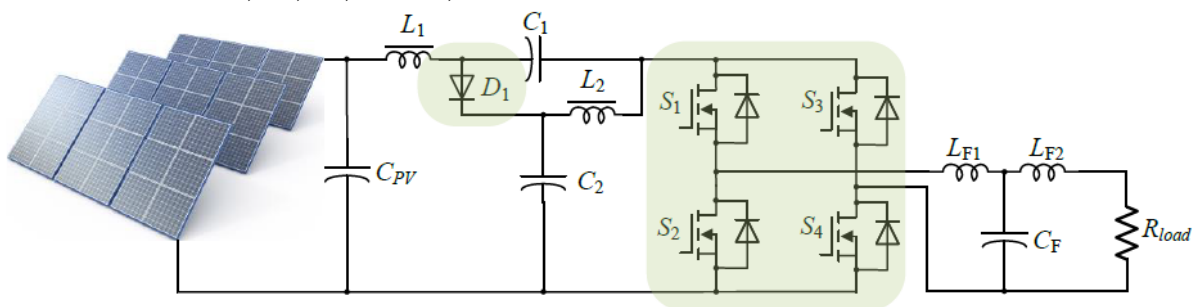

Figure 2. The 2L QZS inverter

The 3L NPC QZSI (Figure 3) was proposed and discussed in detail as a single-phase application in Referene [6]. The study also provides the main design guidelines and the experimental results. The main parts of the topology include the QZS network, which in this case was divided by a neutral point into two symmetrical parts, represented by L1, C1, D1, L2, C2 and L3, C3, D2, L4, and C4; an FB 3L inverter with switches S1, S2, S3, S4, S5, S6, S7, and S8; clamping diodes D3, D4, D5, and D6; and an output filter

LF1, CF, and LF2 feeding the load or connected to the grid. The topology was proved as an e_icient PV converter including maximum power point tracking (MPPT) implementation along with continuous input current and operation in the grid-connected mode. The implementation of this topology under di_erent control approaches is discussed in detail in References. In our study, the SBC approach was used for generating the ST states.

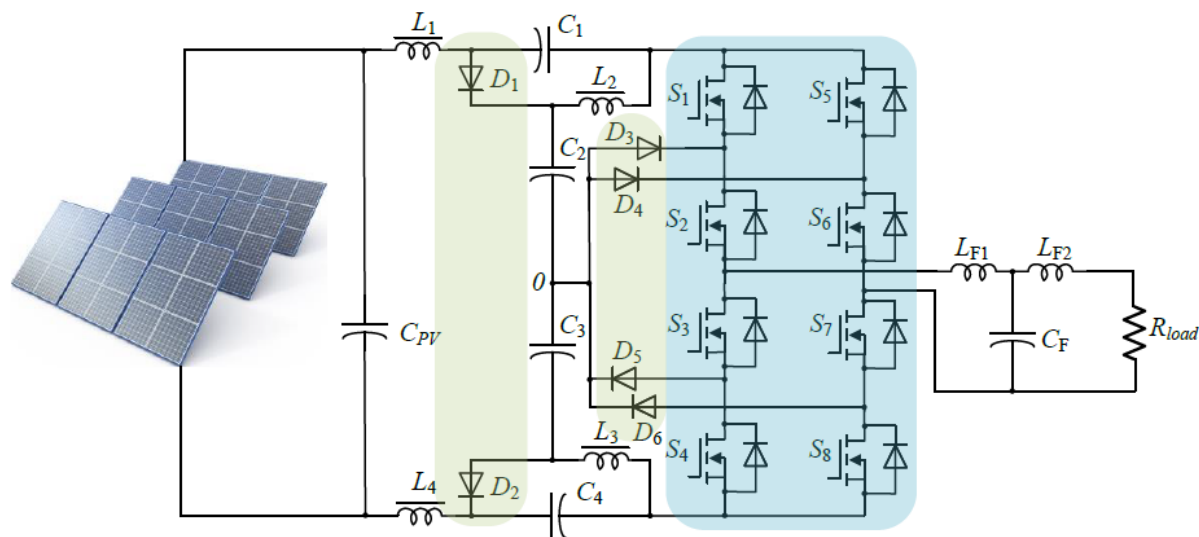

Figure 3. The 3l NPC QZS inverter.

3. DESCRIPTION OF QZS-CMI-BASED GRID-TIE PV POWER SYSTEM

Fig. 4 shows the discussed qZS-CMI-based grid-tie PV power system. The total output voltage of the inverter is a series summation of qZS-HBI cell voltages. Each cell is fed by an independent PV panel. The individual PV power source is an array composed of identical PV panels in parallel and series. A typical PV model is performed by considering both the solar irradiation and the PV panel temperature. A. qZS-CMI

The qZS-CMI combines the qZS network into each HBI module. When the th qZS-HBI is in nonshoot-through states, it will work as a traditional HBI. There are

$$\hat{v}_{DCk} = \frac{1}{1 - 2D_k} v_{PVk} = B_k v_{PVk} \quad v_{Hk} = S_k \hat{v}_{DCk} \quad (1)$$

while in shoot-through states, the qZS-HBI module does not contribute voltage. There are

$$\hat{v}_{DCk} = 0 \quad v_{Hk} = 0, \quad (2)$$

For the qZS-CMI, the synthesized voltage is

$$v_H = \sum_{k=1}^n v_{Hk} = \sum_{k=1}^n S_k \hat{v}_{DCk} \quad (3)$$

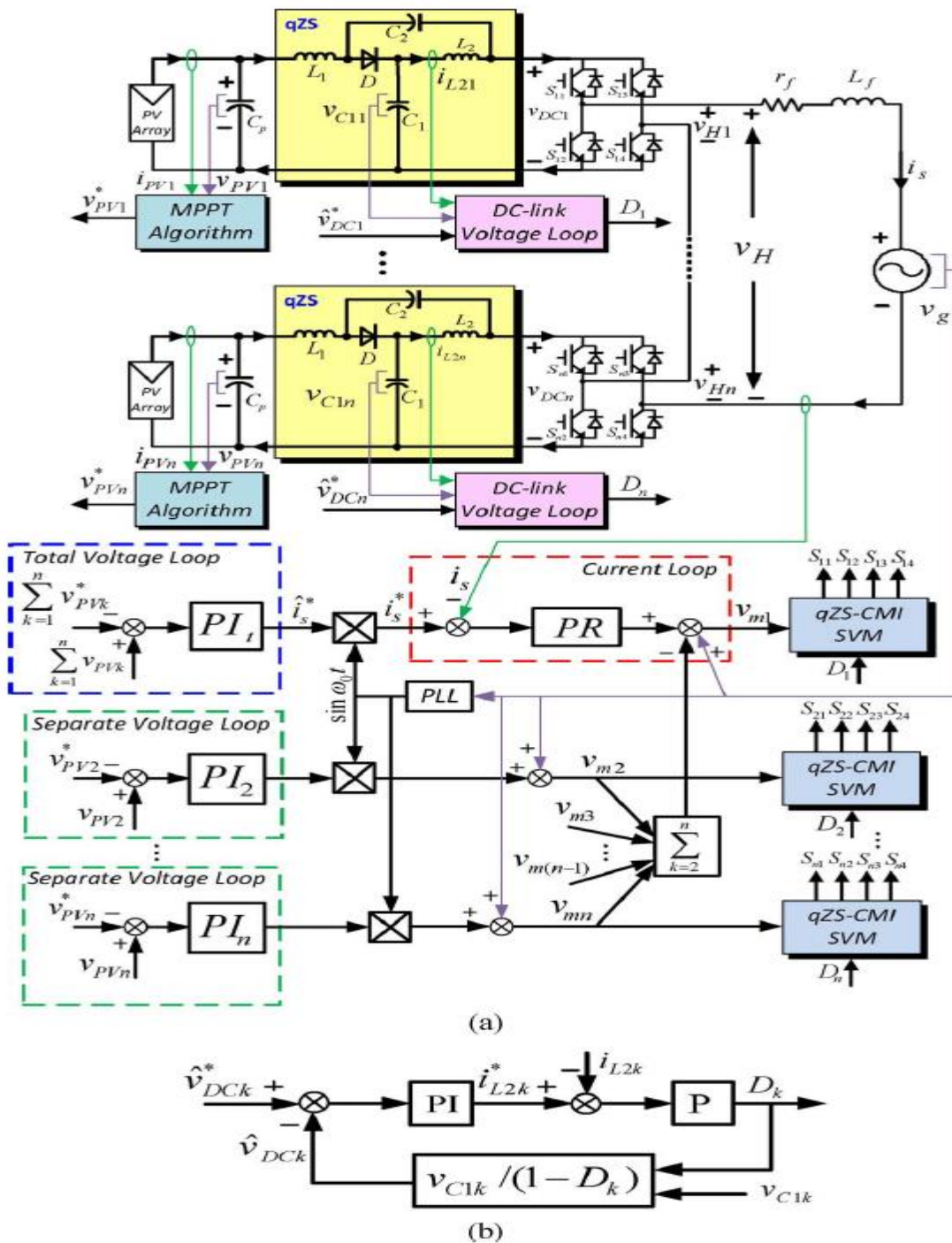

Fig. 1. (a) qZS-CMI based grid-tie PV power system. (b) DC-link peak voltage control.

CONCLUSIONS

In this study, a PV-string with a nominal power level of 1800W was chosen as a case study for

the evaluation of two PV-inverters based on the 2L QZSI full-SiC solution and the 3L NPC QZSI solution with Si MOSFETs. However,

both investigated topologies could be easily up-scaled (with appropriately selected passive components) and safely operated up to twice the higher power level. The main conclusion from our analysis is that the full-SiC 2L QZSI solution has a clear advantage over the 3L NPC QZSI solution with Si MOSFETs. First of all, it simplifies the printed Circuit Board (PCB) and reduces the number of auxiliary components around switches. Secondly, it may provide higher efficiency along with the lower volume of heatsink. It should be mentioned that efficiency and heatsink volume can be used as trade-off parameters for industrial optimization. The heatsink volume increase will lead to the temperature decreasing and to efficiency improvements correspondingly. On the other hand, the reliability and longtime operation of the full-SiC solution is an open question for discussion and can be a limiting factor in industrial implementation.

REFERENCES

- [1] J. Chavarria, D. Biel, F. Guinjoan, C. Meza, and J. J. Negroni, "Energy balance control of PV cascaded multilevel grid-connected inverters under level-shifted and phase-shifted PWMs," *IEEE Trans. Ind. Electron.*, vol. 60, no. 1, pp. 98–111, Jan. 2013.
- [2] F. Filho, H. Z. Maia, T. H. A. Mateus, B. Ozpineci, L. M. Tolbert, and J. O. P. Pinto, "Adaptive selective harmonic minimization based on ANNs for cascade multilevel inverters with varying DC sources," *IEEE Trans. Ind. Electron.*, vol. 60, no. 5, pp. 1955–1962, May 2013.
- [3] S. Kouro, C. Fuentes, M. Perez, and J. Rodriguez, "Single DC-link cascaded H-bridge multilevel multistring photovoltaic energy conversion system with inherent balanced operation," in *Proc. IECON 38th Annu. Conf. IEEE Ind. Electron. Soc.*, Oct. 25–28, 2012, pp. 4998–5005.
- [4] S. Rivera, S. Kouro, B. Wu, J. I. Leon, J. Rodriguez, and L. G. Franquelo, "Cascaded H-bridge multilevel converter multistring topology for large scale photovoltaic systems," in *Proc. IEEE Int. Symp. Ind. Electron.*, Jun. 27–30, 2011, pp. 1837–1844.
- [5] L. Liu, H. Li, Y. Zhao, X. He, and Z. J. Shen, "1 MHz cascaded Z-source inverters for scalable grid-interactive photovoltaic (PV) applications using GaN device," in *Proc. IEEE Energy Conv. Congr. Expo.*, Sep. 17–22, 2011, pp. 2738–2745.
- [6] B. Ge, "Energy Stored Cascade Multilevel Photovoltaic Grid-Tie Power Generation System," China Patent ZL201010234877.0, Jul. 2010, in Chinese.
- [7] Y. Zhou, L. Liu, and H. Li, "A high-performance photovoltaic module integrated converter (MIC) based on cascaded quasi-Z-source inverters (qZSI) using eGaN FETs," *IEEE Trans. Power Electron.*, vol. 28, no. 6, pp. 2727–2738, Jun. 2013.
- [8] D. Sun, B. Ge, F. Z. Peng, H. Abu-Rub, D. Bi, and Y. Liu, "A new grid-connected PV system based on cascaded H-bridge quasi-Z source inverter," in *Proc. IEEE Int. Symp. Ind. Electron.*, May 28–31, 2012, pp. 951–956.
- [9] H. Abu-Rub, A. Igbal, Sk. Moin Ahmed, F. Z. Peng, Y. Li, and B. Ge, "Quasi-Z-source inverter-based photovoltaic generation system with maximum power tracking control using ANFIS," *IEEE Trans. Sustain. Energy*, vol. 4, no. 1, pp. 11–20, Jan. 2013.