

## A MODE-SELECT CIRCUIT ANALYSIS BASED CONTROL OF A POSITIVE BUCK–BOOST CONVERTER

Hassan Ali

### ABSTRACT—

The proposed work is to design a positive buck-boost converter with mode-select circuit and with wide range of input voltages. Four switches produce more switching and conduction losses when the converter operates in high frequency. In order to avoid those losses, we employ mode-select circuit in which the converter can work in three different modes as buck, boost and buck-boost mode. With the mode-select circuit the losses in switches are reduced and by the way the converter efficiency is improved. To lessen the loss of switches as the positive buck-boost converter operates in wide range of supply voltages, it is essential to avoid power converters operating in buck-boost mode. By implying feed-forward techniques, the proposed converter can improve its transient response when the supply voltages are changed. It is typically used to compensate for input variations and provide tighter control response of the output voltage. With the above mentioned techniques the proposed converter can get better power efficiency and extends the battery life. The proposed work was This paper describes a new method for minimizing the transients in the output of a DC-DC converter required for small powered portable electronic applications. The transient problem has been the most serious problem for power supplies needing the output voltage in the mid-range of the input voltage. The maximum transient arises when the input voltage becomes almost equal to the output voltage. Selecting the best approach involves a tradeoff among cost, efficiency, and output noise or ripple. There are various techniques used to solve the problem of transients. However, most of the methods have drawbacks such as comparatively higher transients or lower efficiency because of the longer switching operations. This paper describes few methods already been used to solve the transient problem and points out the demerits of those methods. In addition, a new combination method, which combines buck and boost modes during the transition mode, is described in this paper to minimize the transients at the output of the converters when the input voltage is near to the output voltage. Mathematical equations have been put forward to support the proposed idea for the transient minimization. Simulation results have been added to make a comparative analysis of transient response of this method with respect to the other methods

### 1. INTRODUCTION

A very common power-handling problem, especially for portable applications, powered by batteries such as cellular phones, personal digital assistants (PDAs), wireless and digital subscriber line (DSL) modems, and digital cameras, is the need to provide a regulated non-inverting output voltage from a variable input battery voltage. The battery voltage, when charged or discharged, can be greater than, equal to, or less than the output voltage. But for such small-scale applications, it is very important to regulate the output voltage of the converter with high precision and performance. Thus, a tradeoff

among cost, efficiency, and output transients should be considered.

A common power-handling issue for space-restrained applications powered by batteries is the regulation of the output voltage in the midrange of a variable input battery voltage. Some of the common examples are 3.3 V output with a 3–4.2 V Li cell input, 5 V output with a 3.6–6 V four-cell alkaline input, or a 12 V output with an 8–15 V lead–acid battery input. Recently, with the flourishing of portable devices and the development of semiconductor manufacturing technology, conversion

efficiency, power consumption and size of devices have become the most important design criteria of switching power converters. Power converters are often applied to LED products, notebooks, mobile phones, and car electronic products. For portable applications, in order to provide consumers better conveniences, how to extend battery life and improve the conversion efficiency of power converters are challenges for designers. Therefore, it is essential to develop accurate switching power converters, which can reduce more wasted power energy [1]. A very common power handling problem, especially for portable applications, powered by batteries such as cellular phones, personal digital assistants (PDAs), wireless and digital subscriber line (DSL) modems, and digital cameras, is the need to provide a regulated non-inverting output voltage from a variable input battery voltage. The battery voltage, when charged or discharged, can be greater than, equal to, or less than the output voltage. But for such small-scale applications, it is very important to regulate the output voltage of the converter with high precision and performance. Thus, a trade-off among cost, efficiency, and output transients should be considered [6]. A common power handling issue for space-restrained applications powered by batteries is the regulation of the output voltage in the midrange of a variable input battery voltage. There are various topologies such as inverting buck-boost converters, single-ended primary inductance converters (SEPICs), Cuk converters, isolated buck-boost converters and cascaded buck and boost converters, which can be implemented to maintain a constant output voltage from a variable input voltage.

## 2. DC-TO-DC CONVERTER

DC to DC converters are important in portable electronic devices such as cellular phones and laptop computers, which are supplied with power from batteries primarily. Such electronic devices often contain several sub-circuits, each with its own voltage level requirement different than that supplied by the battery or an external supply (sometimes higher or lower than the supply voltage, and possibly even negative

voltage). Additionally, the battery voltage declines as its stored power is drained. Switched DC to DC converters offer a method to increase voltage from a partially lowered battery voltage thereby saving space instead of using multiple batteries to accomplish the same thing.

Most DC to DC converters also regulate the output voltage. Some exceptions include high-efficiency LED power sources, which are a kind of DC to DC converter that regulates the current through the LEDs, and simple charge pumps which double or triple the input voltage.

There are three kinds of switching mode DC-DC converters, buck, boost and buck-boost. The buck mode is used to reduce output voltage, whilst the boost mode can increase the output voltage. In the buck-boost mode, the output voltage can be maintained either higher or lower than the source but in the opposite.

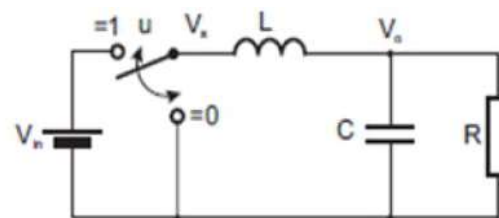

(a) Buck

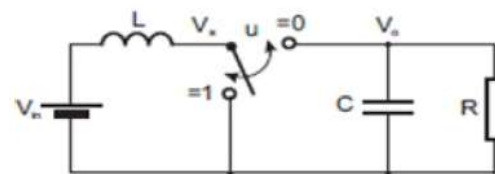

(b) Boost

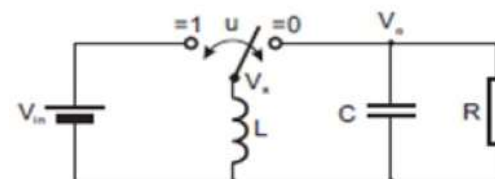

(c) Buck-boost

**Fig. 1. Buck, Boost, Buck-Boost Converter Equivalent Circuit Diagram.**

These converters consist of the same components, an inductor,  $L$ , a capacitor,  $C$  and a switch, which has two states  $u = 1$  and  $u = 0$ . All converters connect to a DC power source with a voltage (unregulated),  $V_{in}$  and provide a regulated voltage,  $V_o$  to the load resistor,  $R$  by controlling the state of the switch. In some situations, the load also could be inductive, for example a DC motor, or approximately, a current load, for example in a cascade configuration. For simplicity, here, only current and resistive loads are to be considered.

### 2.1.1. Working Principles

The working principles of the DC-DC converters can be explained as follows. In the buck mode, when the switch is on position 1, the DC source supplies power to the circuit which results an output voltage across the resistor. When the switch changes its position to 0, the energy stored in the inductor and capacitor will discharge through the resistor. Appropriately controlling the switching position can maintain the output voltage at a desired level lower than the source. In the boost mode, when the switch is on position 1, the circuit is separated into two parts: on the left, the source is charging the inductor; meanwhile the capacitor on the right maintains the output voltage using previously stored energy. When the switch changes its position to 0, both the DC source and energy stored in the inductor will supply power to the circuit on the right, hence boost the output voltage. Again, the output voltage can be maintain at desired level by controlling the switching sequence.

### 2.1.2 Chopper

A chopper is a static device that converts fixed d.c input voltage to a variable d.c output voltage directly. A chopper is a high speed ON/OFF semi-conductor switch. It connects the source to load and disconnects the load from source at a fast speed. In this manner a chopped load voltage is obtained.

A chopper may be thought of d.c equivalent of an a.c transformer having continuously variable turns ratio. Like a transformer, a chopper can be

used to step down or step up the fixed d.c input voltage. If the averaged output voltage is less than the supply voltage then it is a step down chopper and is known as a buck chopper. If the averaged output voltage is greater than the supply voltage then it is a step up chopper and is known as a boost chopper.

## 3. PROPOSED METHOD

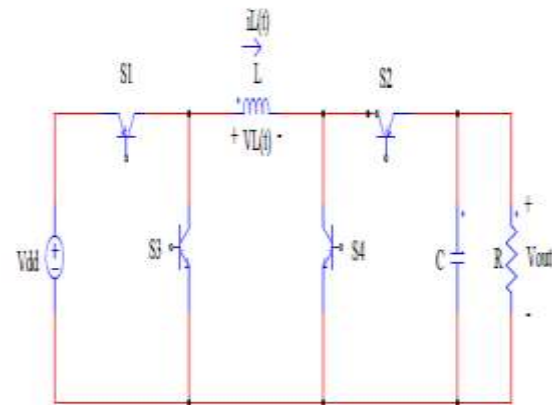

Fig.2 Proposed converter circuit.

In this proposed work, the positive buck-boost converter can operate in buck, boost, and buck-boost mode. The highest ratio occurs in buck-boost mode; the positive buck-boost converter causes switching loss and conduction loss because of its four power transistors. To reduce the loss of switches, as the positive buck-boost converter operates in wide-range of supply voltages, it is necessary to avoid power converters operating in buckboost mode. Therefore, we design a mode-select circuit to detect the battery energy and select the operation mode [1].

When the converter operates in buck mode or boost mode, it only switches two power transistors. The mode-select circuit can reduce the conduction loss and switching loss of the proposed converter, and the power efficiency can be improved. The proposed converter can operate in wide supply voltage range and extend the battery life.

### A. Mode-Select Circuit

The use of four power transistors produces more switching losses and conduction losses when operated in high frequency. To avoid those

losses we utilize mode-select circuit and we can operate in three different modes as buck, boost and buck-boost mode. The mode-select circuit can avoid overlapping of the modes; it can decide the mode to operate when needed. Then it can avoid turning on the power transistors at the same time. Finally, it can determine the operation mode by a control signal from controller. By using this we can extend the battery life and operate the converter in efficient way.

### B. Modes of Operation

Fig.3 (a) shows the proposed converter operating in the charging interval of buck mode; the power transistors S1 and S2 are turned ON and the power transistors S3 and S4 are turned OFF. Fig.3 (b) shows the proposed converter operating in the discharging interval of buck mode; the power transistors S2 and S3 are turned ON and the power transistors S1 and S4 are turned OFF.

Fig.4 (a) shows the proposed converter operating in the charging interval of boost mode; the power transistors S1 and S4 are turned ON and the power transistors S2 and S3 are turned OFF. Fig.4 (b) shows the proposed converter operating in the discharging interval of boost mode; the power transistors S1 and S2 are turned ON and the power transistors S3 and S4 are turned OFF.

Fig.5 (a) shows the proposed converter operating in the charging interval of buck-boost mode; the transistors S1 and S4 are turned ON and the power transistors S2 and S3 are turned OFF. Fig.5 (b) shows the proposed converter operating in discharging interval of buck-boost mode; the power transistors S2 and S3 are turned ON and the power transistors S1 and S4 are turned OFF.

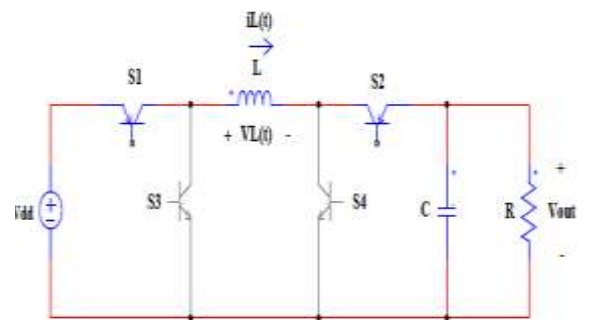

(a)

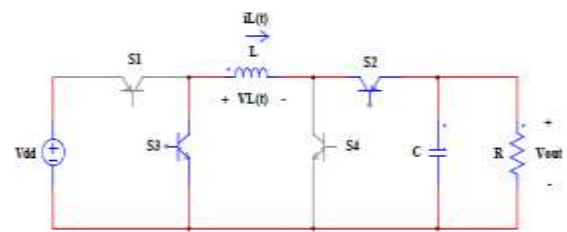

(b)

Fig.3 (a) Charging interval of buck mode. (b) Discharging interval of buck mode.

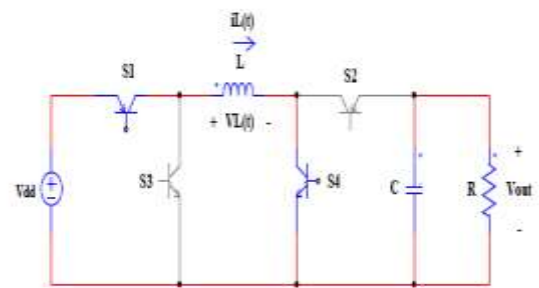

(a)

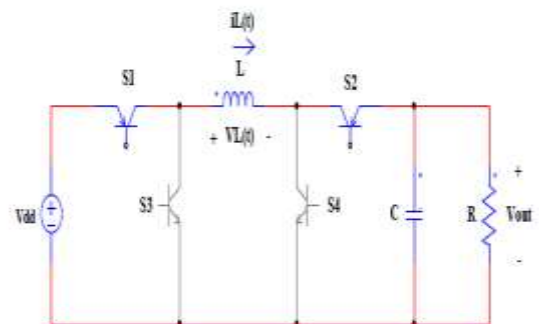

(b)

Fig.4 (a) Charging interval of boost mode. (b) Discharging interval of boost mode

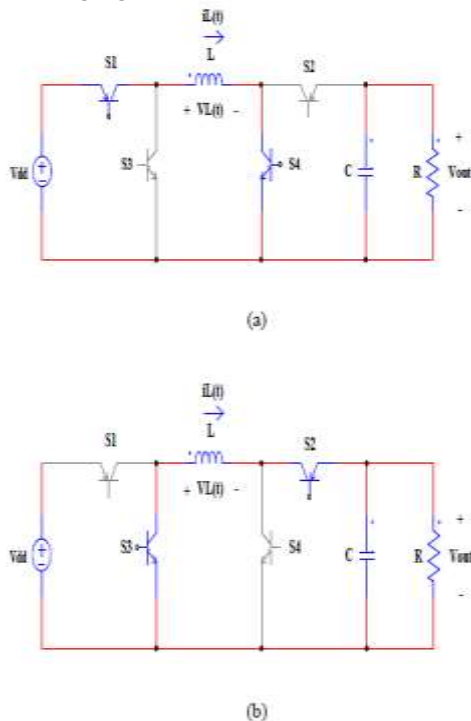

Fig.5 (a) Charging interval of buck-boost mode. (b) Discharging interval of buck-boost mode.

C. PID Controller

By employing PID controller the converter operates effectively and improves the output voltage, when the supply voltage changes. It gives better performance than PI controller, by reducing rise time and increasing gain value the converter responds faster to changes in set point value.

CONCLUSION

By applying the parameter values from Table II for the calculation of buck and boost samples and using (6), just before  $v_{in} \approx v_{out}$ , the rounded ratio of  $\alpha_1$  and  $\beta_1$  is 3:1. Similarly, just after  $v_{in} \approx v_{out}$ , the ratio of  $\alpha_2$  and  $\beta_2$  is found to be 1:2. Thus, we choose  $\alpha_1 = 3$  or three buck cycles and  $\beta_1 = 1$  or one boost cycle for the time period in combination mode A and  $\alpha_2 = 1$  or one buck cycle and  $\beta_2 = 2$  or two boost cycles for the timeperiod in combination mode B. This ratio is presented in terms of block diagram in Fig. 15 for solving the addressed problem.

By applying this combination method of control and simulating the converter, the results are

obtained. The simulation results show that output voltage transients during transition from combination mode A to combination mode B are somehow similar to transients available in transition from combination mode A to buck-boost mode. This voltage variation in this method is about 4%; however, canceling the buck-boost operating mode in between significantly improves the efficiency of the converter.

REFERENCES

[1] A. Chakraborty, A. Khaligh, A. Emadi, and A. Pfaelzer, "Digital combination of buck and boost converters to control a positive buck-boost converter," in Proc. IEEE Power Electron. Spec. Conf., Jun. 2006, vol. 1, pp. 1-6.

[2] A. Chakraborty, A. Khaligh, and A. Emadi, "Combination of buck and boost modes to minimize transients in the output of a positive buck-boost converter," in Proc. IEEE 32nd Ind. Electron. Annu. Conf., Paris, France, Nov. 2006, pp. 2372-2377.

[3] R. W. Erickson, Fundamentals of Power Electronics, 4th ed. Norwell, MA: Kluwer, 1999.

[4] Y. Konishi and Y. F. Huang, "Soft-switching buck boost converter using pulse current regenerative resonant snubber," Electron. Lett., vol. 43, pp. 127-128, Jan. 2007.

[5] L. S. Yang, T. J. Liang, and J. F. Chen, "Analysis and design of a novel three-phase AC-DC buck-boost converter," IEEE Trans. Power Electron., vol. 23, no. 2, pp. 707-714, Mar. 2008.

[6] B. Sahu and G. A. Rincon-Mora, "A low voltage, dynamic, noninverting, synchronous buck-boost converter for portable applications," IEEE Trans. Power Electron., vol. 19, no. 2, pp. 443-452, Mar. 2004.

[7] B. Bryant and M. K. Kazimierzuk, "Derivation of the buck-boost PWM DC-DC converter circuit topology," in Proc. Int. Symp. Circuits Syst., May 2002, vol. 5, pp. 841-844.

[8] Y. Zhang and P. C. Sen, "A new soft-switching technique for buck, boost, and buck-boost converters," IEEE Trans. Ind. Appl., vol. 39, no. 6, pp. 1775-1782, Nov./Dec. 2003.